

Part Number: PT29A-00140-XX

Kit Contents

Item #	Quantity Reqd.	Description
1	1	Molding, LH Front Door
2	1	Molding, LH Rear Door
3	1	Molding, RH Front Door
4	1	Molding, RH Rear Door

Hardware Bag Contents

Item #	Quantity Reqd.	Description
1		
2		

Additional Items Required For Installation

Item #	Quantity Reqd.	Description
1		
2		

Conflicts

None

Recommended Tools

Personal & Vehicle Protection	Notes
Safety Glasses	
Seat & Floor Covers	
Special Tools	Notes
Roller	Hard Rubber Hand Roller, 1" to 3" wide.
Non-intrusive Infrared Temp Probe/Gun	
Installation Tools	Notes
Flexible Scale or Tape Measure	
Masking Tape	2" wide
Clean Lint-free Cloths	
Straight Edge (Plastic)	
Heat Gun (if required to warm surfaces)	
Heat Source	
Special Chemicals	Notes
Simple Green All Purpose Cleaner	½ Strength (1 part Simple Green to 1 part water)

General Applicability

Body Side Molding can be installed on all MY2015 or later Camry models.

Recommended Sequence of Application

Item #	Accessory
1	Body Side Molding
2	Lower Door Molding
3	Door Edge Guards

*Mandatory

Vehicle Service Parts (may be required for reassembly)

Item #	Quantity Reqd.	Description

Legend

 **STOP:** Damage to the vehicle may occur. Do not proceed until process has been complied with.

 **OPERATOR SAFETY:** Use caution to avoid risk of injury.

 **CAUTION:** A process that must be carefully observed in order to reduce the risk of damage to the accessory/vehicle and to ensure a quality installation.

 **TOOLS & EQUIPMENT:** Used in Figures calls out the specific tools and equipment recommended for this process.

 **REVISION MARK:** This mark highlights a change in installation with respect to previous issue.

 **SAFETY TORQUE:** This mark indicates that torque is related to safety.

Care must be taken when installing this accessory to ensure damage does not occur to the vehicle. The installation of this accessory should follow approved guidelines to ensure a quality installation.

These guidelines can be found in the "Accessory Installation Practices" document.

This document covers such items as:-

- Vehicle Protection (use of covers and blankets, cleaning chemicals, etc.).
- Safety (eye protection, rechecking torque procedure, etc.).
- Vehicle Disassembly/Reassembly (panel removal, part storage, etc.).
- Electrical Component Disassembly/Reassembly (battery disconnection, connector removal, etc.).

Please see your Toyota dealer for a copy of this document.

1. Prepare the Vehicle.

STOP (a) Before working on the vehicle, protect the seats and carpets with covers.

STOP (b) The work area, body side moldings, and vehicle door surface temperatures must be between 60°F (16°C) and 110°F (43°C).

(c) Clean the areas of each door as shown in Fig. 1-1 using a ½ strength Simple Green solution (1 part Simple Green to 1 part water).

(d) Wipe the cleaned surfaces with a clean, dry, lint-free cloth.

NOTE: Once cleaned do not contaminate this surface by touching it with your bare hands.

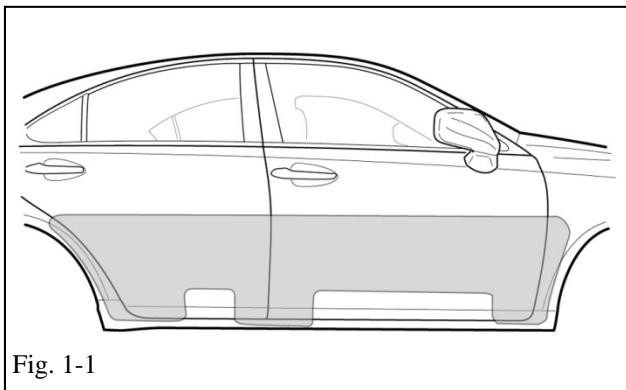

Fig. 1-1

2. Apply Alignment Tape.

(a) Measure 966mm forward from the bottom rear edge of the front door and place a vertical piece of tape on the front door approximately 400mm long (Fig. 2-1).

(b) Place a vertical piece of tape over the door gap between the front and rear doors approximately 400mm long (Fig. 2-1).

(c) Measure 560mm rearward from the front bottom edge of the rear door and place a vertical piece of tape on the rear door approximately 400mm long (Fig. 2-1).

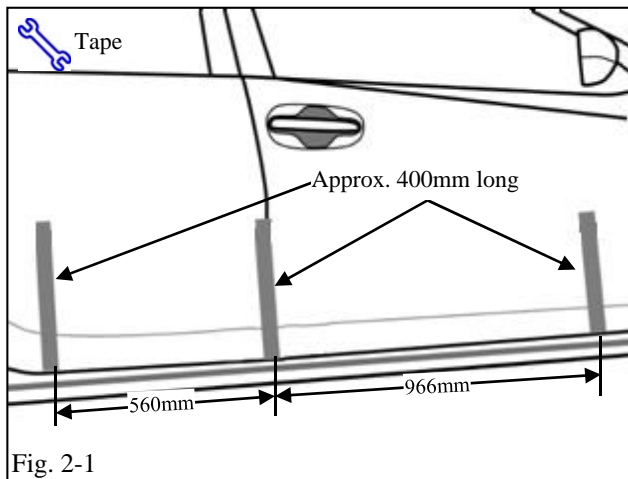
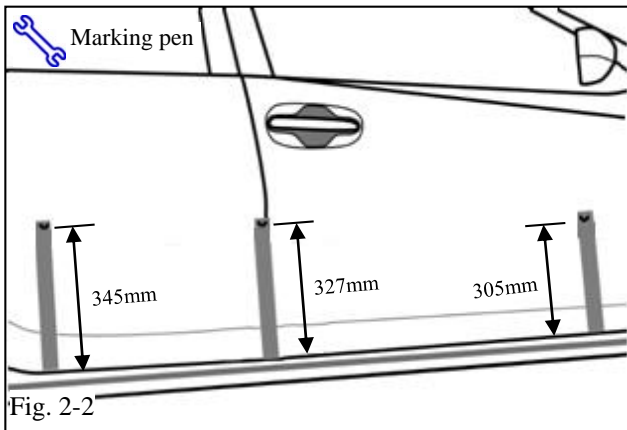

Fig. 2-1



(d) Measure up from the bottom of the door edges and place a horizontal mark on the three vertical pieces of tape (Fig. 2-2).

(1) Front: 305mm

(2) Middle: 327mm

(3) Rear: 345mm

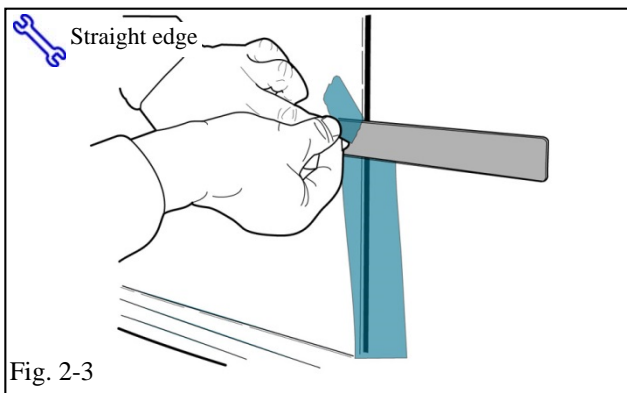

(e) Use a straight edge to tear the vertical tape along a horizontal line at the upper mark (Fig. 2-3 & Fig. 2-4).

(f) Repeat Steps 2(a) to 2(e) for the other side of the vehicle.

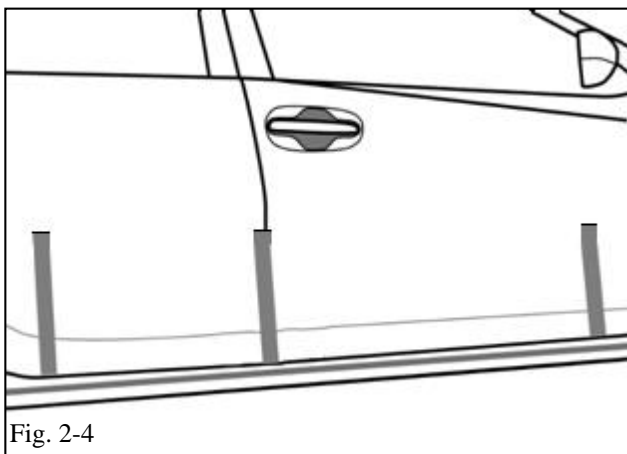



3. Install the Body Side Molding.

 (a) The inside of each of the four moldings is identified as to their correct position on the vehicle.

(b) Start with the RH front door molding. While carefully holding the molding by its edges, pull the plastic tape at the end of the part to remove the orange release liner from the grey acrylic foam tape strips (Fig. 3-1).

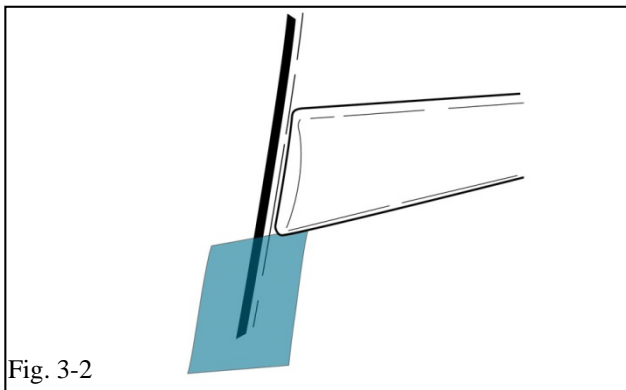
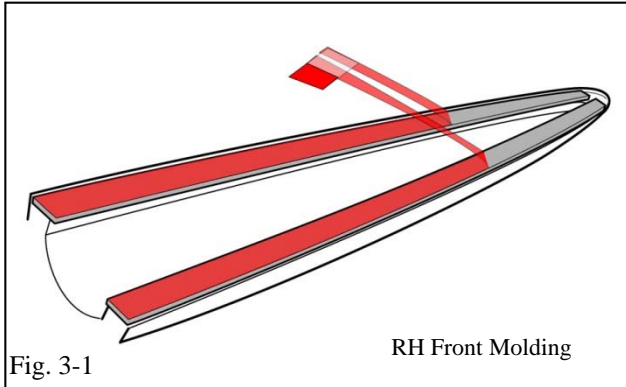
 **NOTE:** Once the release liner is removed from the molding, the surface of the foam tape must not be touched!



 (c) Hold the molding about 1/2" from the surface of the front door and align the rear edge of the molding **6 mm** from the rear edge of the front door (Fig. 3-2 & Fig. 3-3).

(1) The rear bottom edge of the molding aligns vertically with the top edge of the vertical tape strip.

(2) The front portion of the molding aligns with the top edge of the tape strip at the front of the door.

(d) Once the molding is properly aligned, press it to the door surface starting at the rear and working toward the front with a rolling motion.

 **NOTE:** Do not allow both ends to contact and stick to the door before the center contacts.

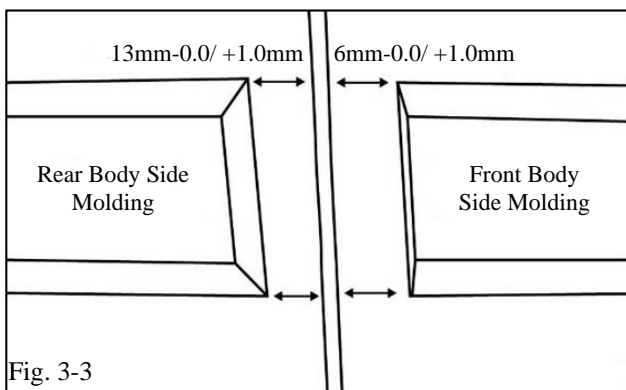

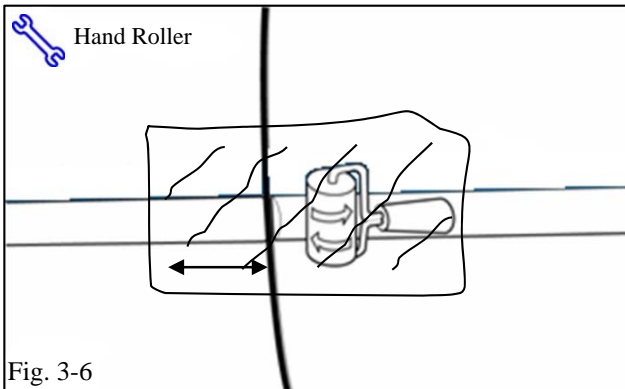
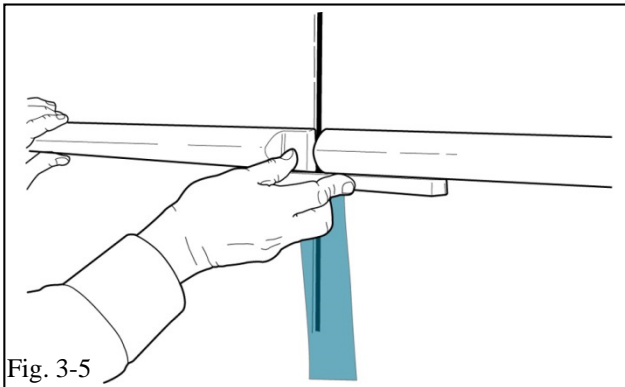
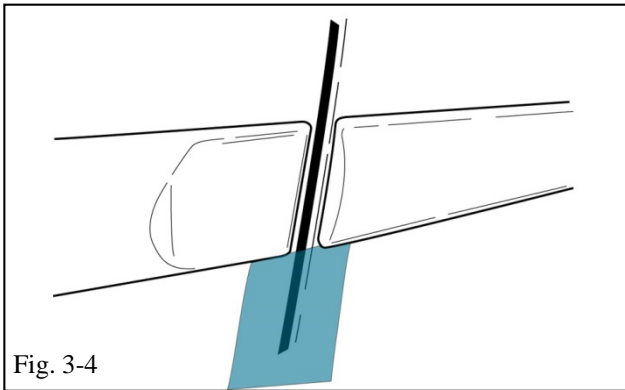

(e) Repeat Steps 3(a) through 3(d) for the RH rear door molding placing the front edge of the molding **13 mm** from the door edge as shown in Fig. 3-3 and Fig. 3-4.

⚠ NOTE: To ensure vertical alignment where the rear and front molding meet between the doors, hold a plastic straight edge against the bottom of the front molding and use it as a guide for the rear molding as shown in Fig. 3-5. Tolerance for alignment in the vertical direction of the front and rear molding in relation to each other is 0.0mm +/-1.0mm.

⚠ (f) Use the hand roller and a clean cloth to roll around the perimeter of the parts with firm pressure to ensure complete adhesion of the tape to the door surface. Use the cloth to protect the sheet metal and the body side molding (Fig. 3-6).

(g) Repeat the entire installation procedure for the other side of the vehicle.

(h) Remove and discard all of the tape strips.

TOYOTA CAMRY/HV 2015 - BODY SIDE MOLDING
Checklist - these points **MUST** be checked to ensure a quality installation.

<u>Check:</u>	<u>Look For:</u>
<p><u>Accessory Function Checks</u></p> <p><input type="checkbox"/> Check visual alignment</p> <p><input type="checkbox"/> Check for proper tape adhesion.</p>	<p>The moldings should be visually straight.</p> <p>The front edge of the rear moldings should be 13 mm away from the front edge of the rear door.</p> <p>The inside rear edge of the front moldings should be 6 mm away from the rear edge of the front doors.</p> <p>Confirm 100% tape adhesion completely around the part between the Body Side Molding and door sheet metal.</p>
<p><u>Vehicle Function Checks</u></p> <p><input type="checkbox"/> None Required</p>	
<p><u>Vehicle Appearance Checks</u></p> <p><input type="checkbox"/> After accessory installation and removal of protective cover(s), perform a visual inspection.</p>	<p>Ensure no damage (including scuffs and scratches) was caused during the installation process. (For PPO installation, refer to Accessory Quality Shipping Standard.)</p>